



**KOLEJ YAYASAN PELAJARAN JOHOR
FINAL EXAMINATION**

COURSE NAME : MICROCONTROLLER
COURSE CODE : DKE 3033
SESSION : DECEMBER 2022
DURATION : 2 HOURS 30 MINUTES

**INSTRUCTION TO CANDIDATES /
ARAHAN KEPADA CALON**

1. This examination paper consists of **ONE (1)** part :/ PART A (100 Marks) /
*Kertas soalan ini mengandungi **SATU (1)** bahagian:* *BAHAGIAN A (100 Markah)*

2. Candidates are not allowed to bring any material to examination room except with the permission from the invigilator. The formula was attached at the back question paper. /
Calon tidak dibenarkan untuk membawa sebarang bahan/nota ke bilik peperiksaan tanpa arahan/kebenaran daripada pengawas.

3. Please check to make sure that this examination pack consists of: /
Pastikan kertas soalan peperiksaan ini mengandungi:
 - i. Question Paper. /
Kertas Soalan.
 - ii. Answering Booklet. /
Buku Jawapan.

**DO NOT TURN THIS PAGE UNTIL YOU ARE TOLD TO DO SO /
JANGAN BUKA KERTAS SOALAN INI SEHINGGA DIBERITAHU**

This examination paper consists of **8** printed pages including front page
*Kertas soalan ini mengandungi **8** muka surat termasuk kulit hadapan*

This part contains of **FOUR (4)** questions. Answer **FOUR (4)** questions in the Answering Booklet.

Bahagian ini mempunyai EMPAT (4) soalan. Jawab EMPAT (4) soalan di dalam Buku Jawapan.

QUESTION 1/ SOALAN 1

- a) List three (3) types of system bus in the Microcontroller 8051.

(3 marks/ 3 markah)

- b) Show the active register bank and address of R0 to R7 for the following instruction.

MOV PSW, # 0C8H

(10 marks/ 10 markah)

- c) Based on schematic in **Figure 1**, show the address range for devices 2764 and 6264 below.

(12marks/ 12 markah)

- a) *Senaraikan tiga (3) jenis bas sistem yang terdapat dalam Pengawal Mikro 8051.*

- b) *Tunjukkan daftar bank yang aktif dan alamat bagi R0 hingga R7 untuk arahan di bawah.*

MOV PSW, # 0C8H

- c) *Berdasarkan skematik dalam Rajah 1, tunjukkan julat alamat untuk peranti 2764 dan 6264 di bawah.*

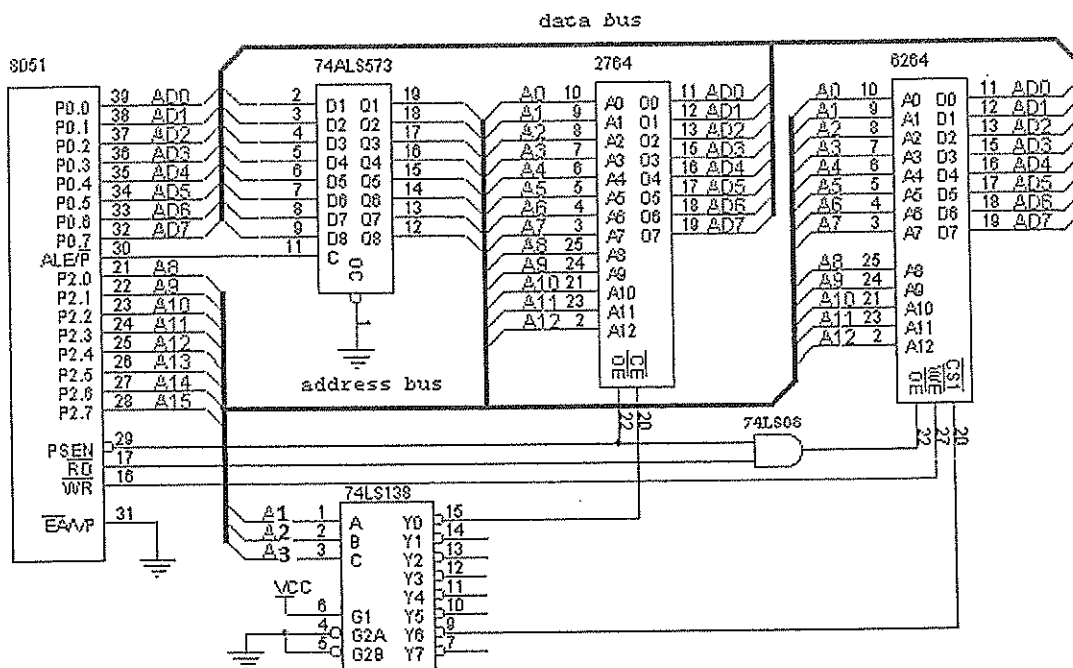

Figure 1/ Rajah 1

QUESTION 2/ SOALAN 2

a) Show the status of the CY, AC and P flags after the execution of the following arithmetic instructions

```
MOV    A,#156
ADD    A,#101
```

(5 marks/5 markah)

b) Describe the mnemonic instruction in 8051 Microcontroller below:

- i. SUBB A,#data
- ii. DEC Rn
- iii. MOVC A,@A+DPTR
- iv. CJNE A,#data,rel
- v. SJMP rel

(5 marks/ 8 markah)

c) Convert Program Q2 into machine codes (hex codes)

```

Program Q2
ORG      10H
ULANG:   MOV      DPTR,#0090H
          CLR      A
SEMULA:  MOVC     A,@A+PC
          JZ       ULANG
          MOV      P2,A
          INC      DPTR
          SJMP    SEMULA
          END

```

(15marks/ 15 markah)

a) Tunjukkan status bendera CY, AC dan P setelah pelaksanaan arahan arithmetic berikut.

```

MOV      A,#156
ADD      A,#101

```

b) Huraikan arahan mnemonik dalam Mikropengawal 8051 di bawah:

- i. SUBB A,#data
- ii. DEC Rn
- iii. MOVC A,@A+DPTR
- iv. CJNE A,#data,rel
- v. SJMP rel

c) Tukarkan Aturcara Q2 kepada kod mesin (kod heks).

```

Aturcara Q2
ORG      10H
ULANG:   MOV      DPTR,#0090H
          CLR      A
SEMULA:  MOVC     A,@A+PC
          JNZ     ULANG
          MOV      P2,A
          INC      DPTR
          SJMP    SEMULA
          END

```

QUESTION 3/ SOALAN 3

- a) State two (2) types of Timer/Counter in 8051 Microcontroller.

(2 marks/ 2 markah)

- b) Build an assembly language program to output a 100kHz square wave on pin 1 of port 1 (P1.1) using Timer 1. Assuming a 12MHz oscillator is used with the duty cycle is 50%.

(13 marks/ 13 markah)

- c) Based on Program 3 below, shows the delay subroutine in the program. Assuming a 11.059 MHz oscillator is used.

```

                                Program 3
DELAY:    MOV    TMOD,#10H
          MOV    R0,#200
          ULANG: MOV    TH1,#9EH
          MOV    TL1,#58H
          SETB   TR1
          LOOP:  JNB    TF1,LOOP
          CLR    TR1
          CLR    TF1
          DJNZ   R0,ULANG
          RET

```

(10marks/ 10 markah)

- a) Nyatakan dua (2) jenis Pemasa/Pembilang dalam Pengawal Mikro 8051.

- b) Bina aturcara bahasa mesin untuk keluaran 100kHz, menggunakan gelombang segi empat pada pin 1, menggunakan liang keluaran 1 (P1.1) dan menggunakan Pemasa 1. Anggapkan pengayun yang digunakan ialah 12MHz dengan kitaran tugas ialah 50%.

- c) Berdasarkan *Aturcara 3* di bawah, tunjukkan subrutin lengah yang digunakan dalam *aturcara* tersebut. Anggap pengayun 11.059 MHz digunakan.

Aturcara 3

```

DELAY:    MOV  TMOD,#10H
          MOV  R0,#200
          MOV  TH1,#9EH
          MOV  TL1,#58H
          SETB TR1
LOOP:     JNB  TF1,LOOP
          CLR  TR1
          CLR  TF1
          DJNZ R0,ULANG
          RET

```

QUESTION 4/ SOALAN 4

- a) Build the instructions to enable the serial interrupt, Timer 0 interrupt and external interrupt 1 (INT1).

(2 marks/ 2 markah)

- b) The following instruction is executed by an 8051 microcontroller. List the sequence in which the interrupts are serviced.

MOV IP, #00001100B

(5 marks/ 5 markah)

- c) Build the assembly language program that detects the condition (logic status) of switches and configures the LED lit pattern based on the **Table 4** and **Figure 4** below. If an external interrupt 1 (INT1) occurs by detecting a HIGH-to-LOW transition at P3.3, only one led will lit and blink 5 times.

Table 4

S4	S3	S2	S1	LEDS
0 (closed)	0 (closed)	0 (closed)	1 (opened)	4 LEDs lit(ON)
0 (closed)	0 (closed)	1 (opened)	0 (closed)	A single LED will lit and move from right to left
0 (closed)	1 (opened)	0 (closed)	0 (closed)	4 LEDs will blink continuously
Other Conditions				All LEDs will blink continuously

(18 marks/18 markah)

- a) Bina arahan-arahan untuk menghidupkan sampukan sesiri, sampukan Pemasa 0 dan sampukan luaran 1 (INT1).
- b) Arahan berikut dilaksanakan oleh mikropengawal 8051. Senaraikan aturan jujukan dimana sampukan dilayan.

MOV IP, #00001100B

- c) Bina aturcara bahasa himpunan yang mengesan keadaan (status logik) suis-suis berkenaan dan konfigurasi corak nyalaan LED berdasarkan **Jadual 4** dan **Rajah 4** di bawah. Jika sampukan luaran 1 (INT1) berlaku dengan pengesanan peralihan TINGGI-ke-RENDAH pada P3.3, hanya satu led menyala dan berkelip 5 kali.

Jadual 4

S4	S3	S2	S1	LED
0 (Tutup)	0 (Tutup)	0 (Tutup)	1 (Buka)	4 LED menyala(ON)
0 (Tutup)	0 (Tutup)	1 (Buka)	0 (Tutup)	Satu LED menyala dan bergerak dari kanan ke kiri
0 (Tutup)	1 (Buka)	0 (Tutup)	0 (Tutup)	4 LED berkelip secara berterusan
Keadaan-keadaan Lain				Semua LED berkelip secara berterusan

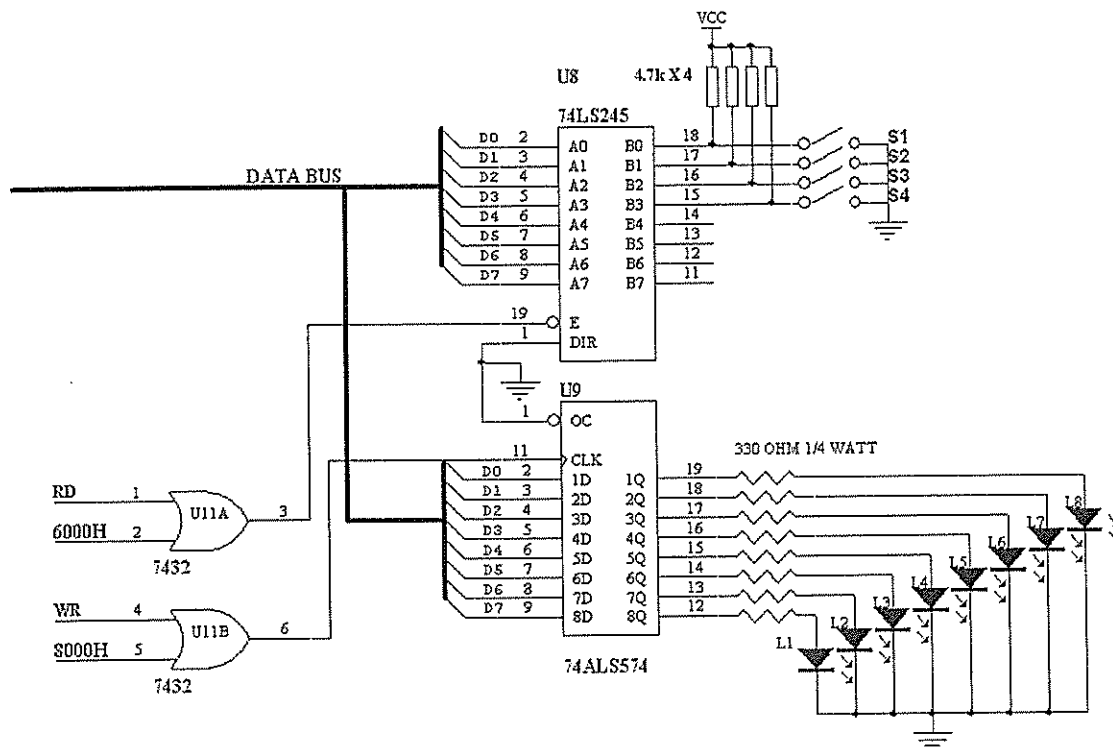

Figure 4/ Rajah 4

[100 MARKS/100 MARKAH]

END OF QUESTION PAPER/ KERTAS SOALAN TAMAT