



**KOLEJ YAYASAN PELAJARAN JOHOR
ONLINE FINAL EXAMINATION**

COURSE NAME : STRENGTH OF MATERIAL
COURSE CODE : DKM 2093
EXAMINATION : DISEMBER 2021
DURATION : 3 HOURS

INSTRUCTION TO CANDIDATES

1. This examintaion paper consists of **ONE (1)** part : / PART A (100 Marks) /
*Kertas soalan ini mengandungi **SATU (1)** bahagian:* BAHAGIAN A (100 Markah)
2. Students are allowed to refer to resources such as lecture notes, books, internet or any other relevant resources. /
Pelajar dibenarkan merujuk kepada sumber seperti nota kuliah, buku, internet atau mana – mana sumber yang berkaitan.
3. Answer ALL questions in the answer sheet which is A4 size paper (or other paper with the consent of the relevant lecturer). /
Jawab SEMUA soalan di dalam kertas jawapan iaitu kertas bersaiz A4 (atau lain-lain kertas dengan persetujuan pensyarah berkaitan).
4. Write your details as follows in the upper left corner for each answer sheet: /
Tulis butiran anda sepertimana berikut di penjuru atas kiri bagi setiap kertas jawapan:
 - i. Student Full Name / *Nama Penuh Pelajar*
 - ii. Identification Card (I/C) No. / *No. KadPengenalan*
 - iii. Class Section / *SeksyenKelas*
 - iv. Course Code / *KodKursus*
 - v. Course Name / *NamaKursus*
 - vi. Lecturer Name / *NamaPensyarah*
5. Each answer sheet must have a page number written at the bottom right corner. /
Setiap helai kertas jawapan mesti ditulis nombor mukasurat di penjuru bawah kanan.
6. Answers should be handwritten, neat and clear. /
Jawapan hendaklah ditulis tangan, kemas dan jelas.

**DO NOT TURN THIS PAGE UNTIL YOU ARE TOLD TO DO SO /
JANGAN BUKA KERTAS SOALAN INI SEHINGGA DIBERITAHU**

This examination paper consists of **19** printed pages including front page
*Kertas soalan ini mengandungi **19** mukasurat termasuk kulit hadapan*

This part contains of **FIVE (5)** questions.

Answer **FOUR (4)** question only in the answer booklet.

Bahagian ini mempunyai LIMA (5) soalan.

Jawab EMPAT (4) soalan sahaja di dalam buku jawapan.

QUESTION 1/ SOALAN 1

Figure 1 shown the temperature of the bar is -45°C and knowing that a close fit exist at both of the rigid supports when the temperature is $+24^{\circ}\text{C}$. Use the values $E= 200\text{GPa}$ and $\alpha= 11.7 \times 10^{-6} / ^{\circ}\text{C}$ for steel.

- a) Find the change of temperature and deformation of length of steel bar.

(10 marks/ markah)

- b) Determine the values of the stress in portions AC and CB of the steel bar

(15 marks/ markah)

Rajah 1 menunjukkan keluli bar yang mempunyai suhu -45°C . Kedua-dua penghujung dalam keadaan rapat dengan suhu $+24^{\circ}\text{C}$. Gunakan nilai $E= 200\text{GPa}$ dan $\alpha = 11.7 \times 10^{-6} / ^{\circ}\text{C}$ bagi keluli.

- a) Carikan nilai perubahan bagi suhu dan perubahan panjang pada keluli bar.

- b) Tentukan nilai tegasan bagi tegasan pada bahagian AC dan CB pada keluli bar itu.

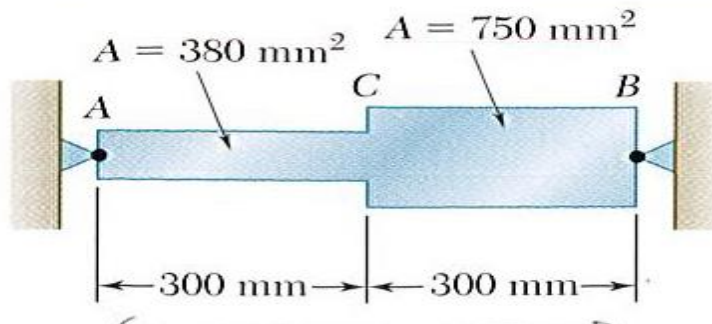

Figure 1/ Rajah 1

QUESTION 2/ SOALAN 2

- a) Explain stress concentration at torque application and give **four (4)** stress concentration caused by torque application.

(8 marks/markah)

- b) A hollow cylindrical steel shaft is 1.5 m long and has inner and outer diameters respectively equal to 40 and 60 mm as shown in **Figure 2**.

- i. What is the largest torque that can be applied to the shaft if the shearing stress is not exceed 120 MPa and determine minimum value of the shearing stress in the shaft.

(11 marks/markah)

- ii. Determine torque should be applied to the end of the shaft as shown in Figure 2 to produce a twist of 2° ? Use the value $G = 77 \text{ GPa}$ for the steel.

(6 marks/markah)

- a) *Terangkan ketumpatan tegasan pada penggunaan daya kilas dan berikan **empat (4)** contoh ketumpatan tegasan yang berlaku pada penggunaan daya kilas.*

- b) *Sebuah keluli berongga berbentuk silinder sepanjang 1.5 m dan mempunyai diameter dalaman dan luaran 40 mm dan 60 mm masing-masing seperti yang ditunjukkan dalam **rajah 2**.*

- i. *Apakah daya kilas terbesar yang boleh digunakan pada aci itu jika tegasan ricih tidak melebihi 120 MPa dan nilai tegasan ricih minimum pada aci tersebut.*
- ii. *Berapakah nilai daya kilas yang perlu dikenakan pada penghujung aci seperti **Rajah 2** untuk menghasilkan putaran sebanyak 2° ? Diberi nilai $G = 77 \text{ GPa}$ pada keluli itu.*

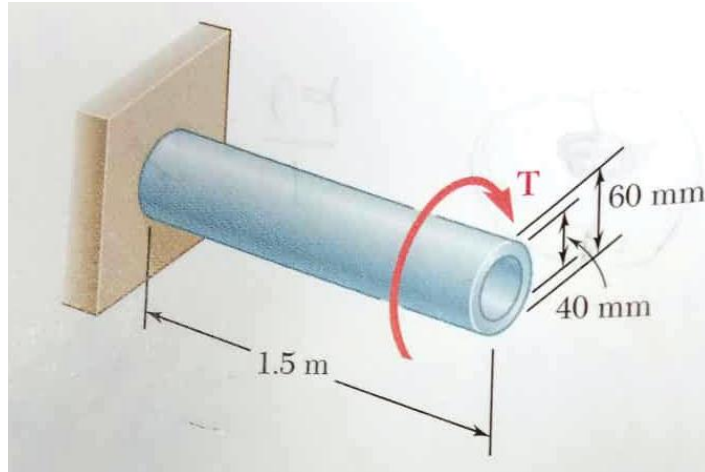

Figure 2/ *Rajah 2*

QUESTION 3/ SOALAN 3

For the given state of stress as shown in **Figure 3**,

- i. Determine the principal planes and the principal stresses and the orientation of the planes of maximum in-plane shearing stress.

(20 marks/ markah)

- ii. Determine the maximum shearing stress and the corresponding normal stress.

(5 marks/ markah)

Bagi satah tegasan seperti ditunjukkan dalam **Rajah 3**:

- i. Tentukan satah utama dan tegasan satah dan orientasi satah bagi tegasan ricih satah yang maksimum.

- ii. Tentukan tegasan ricih maksimum dan tegasan normal

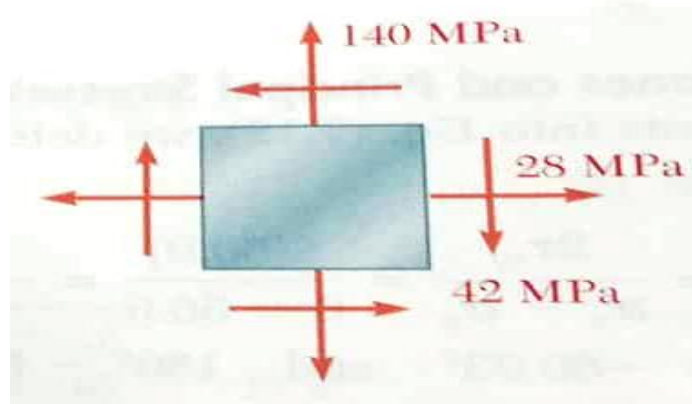

Figure 3/ Rajah 3

QUESTION 4/ SOALAN 4

Knowing that the allowable stress for the steel used is 160 Mpa,

- i. Find the shear and bending- moment diagrams for the beam and loading shown in **Figure 4.**

(15 marks/markah)

- ii. Draw the shear and bending- moment from (a) to shear and bending- moment diagrams.

(5 marks/markah)

- iii. Select the most economical S- shape beam to support the loading shown.

(5 marks/ markah)

Diketahui tegasan yang dibenarkan bagi keluli ialah 160 Mpa,

- i. Carikan daya ricih dan momen lentur bagi rasuk yang mempunyai beban seperti ditunjukkan dalam **Rajah 4.***

- ii. Lukiskan gambar rajah daya ricih dan momen lentur bagi daya ricih dan momen lentur daripada (a).*

- iii. Pilih rasuk berbentuk-S yang sesuai untuk menyokong beban di bawah.*

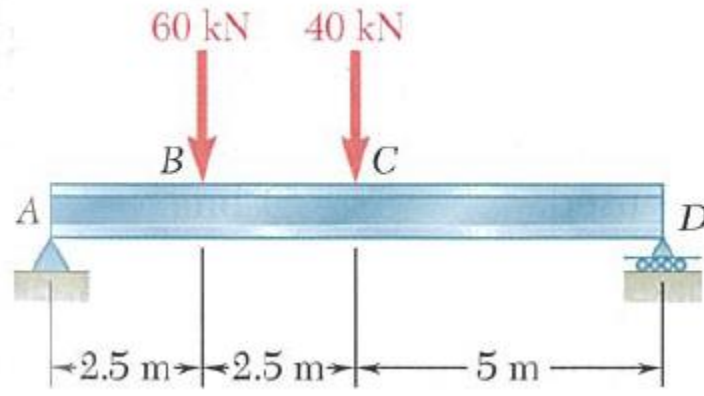

Figure 4/ *Rajah 4*

QUESTION 5/ SOALAN 5

a) What is the meaning of transverse loads?

(5marks/ *markah*)

b) The beam shown in **Figure 5** is made of a nylon for which the allowable stress is 24 MPa in tension and 30 MPa in compression.

i. Find the moment of inertia

(10marks/ *markah*)

ii. Determine the largest moment that can be applied to the beam.

(10marks/ *markah*)

a) *Apakah maksud beban melintang?*

b) *Sebuah aci seperti yang ditunjukkan pada **Rajah 5** dibuat daripada nilon yang mempunyai tegasan yang dibenarkan ialah 24 MPa dalam keadaan tegangan dan 30 MPa dalam keadaan mampatan.*

i. *Tentukan momen inersia*

ii. *Tentukan nilai momen terbesar untuk dikenakan pada aci itu.*

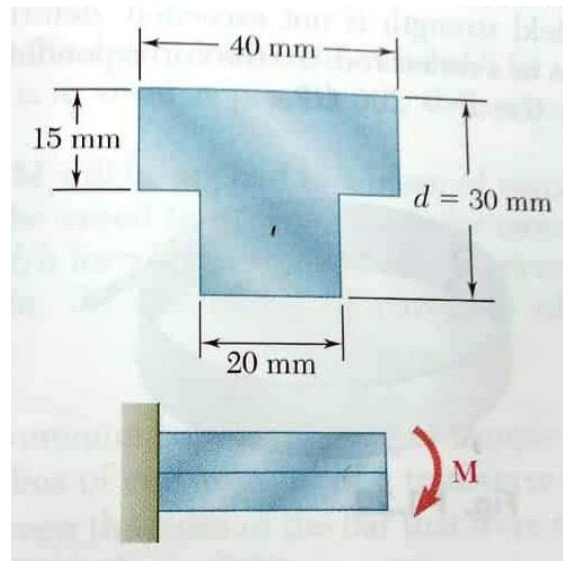

Figure 5/ *Rajah 5*

[60 MARKS/ *MARKAH*]

END OF QUESTION PAPER/ *KERTAS SOALAN TAMAT*

EQUATIONS AND TABLE /RUMUS DAN JADUAL

$\sigma = \frac{P}{A} = \text{stress}$ $\varepsilon = \frac{\delta}{L} = \text{normal strain}$	$\alpha (\Delta T) L + \frac{PL}{AE} = 0$ $P = -AE \alpha (\Delta T)$ $\sigma = \frac{P}{A} = -E \alpha (\Delta T)$
$\delta T = \alpha \Delta T L$	$\tau = G\gamma$
$\tau_{\text{ave}} = \frac{P}{A}$	$\tau_{\text{max}} = \frac{Tc}{J} \quad \text{and} \quad \tau = \frac{T\rho}{J}$
$\sigma = \frac{F}{A_{\theta}} = \frac{P \cos \theta}{\frac{A_0}{\cos \theta}} = \frac{P}{A_0} \cos^2 \theta$ $\tau = \frac{V}{A_{\theta}} = \frac{P \sin \theta}{\frac{A_0}{\cos \theta}} = \frac{P}{A_0} \sin \theta \cos \theta$	$\gamma_{\text{max}} = \frac{c\phi}{L}$
$FS = \frac{\sigma_u}{\sigma_{\text{all}}}$	$\gamma_{\text{max}} = \frac{\tau_{\text{max}}}{G} = \frac{Tc}{JG}$
$\delta = \sum \frac{P_i L_i}{A_i E_i}$	$\phi = \sum \frac{T_i L_i}{J_i G_i}$
$\delta = \delta_L + \delta_R = 0$	$P = T\omega = 2\pi f T$ $T = \frac{P}{\omega} = \frac{P}{2\pi f}$

$\nu = \left \frac{\text{lateral strain}}{\text{axial strain}} \right = - \frac{\varepsilon_y}{\varepsilon_x} =$	$\tau_{\max} = \frac{Tc}{J}$ $\frac{J}{c} = \frac{\pi c^3}{2} = \frac{T}{\tau_{\max}} \quad (\text{solid shafts})$ $\frac{J}{c_2} = \frac{\pi}{2c_2} (c_2^4 - c_1^4) = \frac{T}{\tau_{\max}} \quad (\text{hollow shaft})$
$\sigma_m = \frac{Mc}{I} = \frac{M}{S}$ <p>I = section moment of inertia</p> $S = \frac{I}{c} = \text{section modulus}$	$S = \frac{I}{c} = \frac{\frac{1}{12}bh^3}{h/2} = \frac{1}{6}bh^3 = \frac{1}{6}Ah$
$\sigma_m = \frac{Mc}{I}$	$\frac{1}{\rho} = \frac{M}{EI}$
$\sigma_x = -\frac{My}{I} \quad \sigma_m = \frac{ M c}{I} = \frac{ M }{S}$	$\sigma_m = K \frac{Mc}{I}$
$\sigma_m \leq \sigma_{all}$ $S_{\min} = \frac{ M _{\max}}{\sigma_{all}}$	$\sigma_m \leq \sigma_{all}$ $S_{\min} = \frac{ M _{\max}}{\sigma_{all}}$
$q = \frac{\Delta H}{\Delta x} = \frac{VQ}{I} = \text{shear flow}$	$\tau_{ave} = \frac{\Delta H}{\Delta A} = \frac{q \Delta x}{\Delta A} = \frac{VQ}{I} \frac{\Delta x}{t \Delta x}$ $= \frac{VQ}{It}$

$\tau_{xy} = \frac{VQ}{Ib} = \frac{3V}{2A} \left(1 - \frac{y^2}{c^2} \right)$ $\tau_{\max} = \frac{3V}{2A}$	$\tau_{ave} = \frac{VQ}{It}$ $\tau_{\max} = \frac{V}{A_{web}}$
$\sigma_{x'} = \frac{\sigma_x + \sigma_y}{2} + \frac{\sigma_x - \sigma_y}{2} \cos 2\theta + \tau_{xy} \sin 2\theta$ $\sigma_{y'} = \frac{\sigma_x + \sigma_y}{2} - \frac{\sigma_x - \sigma_y}{2} \cos 2\theta - \tau_{xy} \sin 2\theta$ $\tau_{x'y'} = -\frac{\sigma_x - \sigma_y}{2} \sin 2\theta + \tau_{xy} \cos 2\theta$	
$q = \tau t = \frac{VQ}{I}$	
$(\sigma_{x'} - \sigma_{ave})^2 + \tau_{x'y'}^2 = R^2$ <p>where</p> $\sigma_{ave} = \frac{\sigma_x + \sigma_y}{2} \quad R = \sqrt{\left(\frac{\sigma_x - \sigma_y}{2} \right)^2 + \tau_{xy}^2}$	
$\sigma_{\max, \min} = \frac{\sigma_x + \sigma_y}{2} \pm \sqrt{\left(\frac{\sigma_x - \sigma_y}{2} \right)^2 + \tau_{xy}^2}$ $\tan 2\theta_p = \frac{2\tau_{xy}}{\sigma_x - \sigma_y}$ <p>Note: defines two angles separated by 90°.</p>	

$$\tau_{\max} = R = \sqrt{\left(\frac{\sigma_x - \sigma_y}{2}\right)^2 + \tau_{xy}^2}$$

$$\tan 2\theta_s = -\frac{\sigma_x - \sigma_y}{2\tau_{xy}}$$

Note: defines two angles separated by 90° and

offset from θ_p by 45°

$$\sigma' = \sigma_{ave} = \frac{\sigma_x + \sigma_y}{2}$$

$$\sigma_{ave} = \frac{\sigma_x + \sigma_y}{2} \quad R = \sqrt{\left(\frac{\sigma_x - \sigma_y}{2}\right)^2 + \tau_{xy}^2}$$

$$\sigma_{\max, \min} = \sigma_{ave} \pm R$$

$$\tan 2\theta_p = \frac{2\tau_{xy}}{\sigma_x - \sigma_y}$$

Appendix C. Properties of Rolled-Steel Shapes
(SI Units)

W Shapes
(Wide-Flange Shapes)

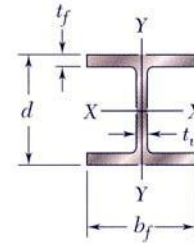

Designation†	Area A, mm ²	Depth d, mm	Flange		Web Thick- ness t _w , mm	Axis X-X			Axis Y-Y		
			Width b _f , mm	Thick- ness t _f , mm		I _x 10 ⁶ mm ⁴	S _x 10 ³ mm ³	r _x mm	I _y 10 ⁶ mm ⁴	S _y 10 ³ mm ³	r _y mm
W920 × 446	57000	933	423	42.70	24.0	8470	18200	385	540	2550	97.3
201	25600	903	304	20.10	15.2	3250	7200	356	94.4	621	60.7
W840 × 299	38100	855	400	29.20	18.2	4790	11200	355	312	1560	90.5
176	22400	835	292	18.80	14.0	2460	5890	331	78.2	536	59.1
W760 × 257	32600	773	381	27.10	16.6	3420	8850	324	250	1310	87.6
147	18700	753	265	17.00	13.2	1660	4410	298	52.9	399	53.2
W690 × 217	27700	695	355	24.80	15.4	2340	6730	291	185	1040	81.7
125	16000	678	253	16.30	11.7	1190	3510	273	44.1	349	52.5
W610 × 155	19700	611	324	19.00	12.7	1290	4220	256	108	667	74.0
101	13000	603	228	14.90	10.5	764	2530	242	29.5	259	47.6
W530 × 150	19200	543	312	20.30	12.7	1010	3720	229	103	660	73.2
92	11800	533	209	15.60	10.2	552	2070	216	23.8	228	44.9
66	8370	525	165	11.40	8.9	351	1340	205	8.57	104	32.0
W460 × 158	20100	476	284	23.90	15.0	796	3340	199	91.4	644	67.4
113	14400	463	280	17.30	10.8	556	2400	196	63.3	452	66.3
74	9450	457	190	14.50	9.0	333	1460	188	16.6	175	41.9
52	6630	450	152	10.80	7.6	212	942	179	6.34	83.4	30.9
W410 × 114	14600	420	261	19.30	11.6	462	2200	178	57.2	438	62.6
85	10800	417	181	18.20	10.9	315	1510	171	18.0	199	40.8
60	7580	407	178	12.80	7.7	216	1060	169	12.1	136	40.0
46.1	5890	403	140	11.20	7.0	156	774	163	5.14	73.4	29.5
38.8	4990	399	140	8.80	6.4	127	637	160	4.04	57.7	28.5
W360 × 551	70100	455	418	67.60	42.0	2260	9930	180	825	3950	108
216	27600	375	394	27.70	17.3	712	3800	161	283	1440	101
122	15500	363	257	21.70	13.0	365	2010	153	61.5	479	63.0
101	12900	357	255	18.30	10.5	302	1690	153	50.6	397	62.6
79	10100	354	205	16.80	9.4	227	1280	150	24.2	236	48.9
64	8140	347	203	13.50	7.7	178	1030	148	18.9	186	48.2
57.8	7220	358	172	13.10	7.9	161	899	149	11.1	129	39.2
44	5730	352	171	9.80	6.9	122	693	146	8.18	95.7	37.8
39	4980	353	128	10.70	6.5	102.0	578	143	3.75	58.6	27.4
32.9	4170	349	127	8.50	5.8	82.7	474	141	2.91	45.8	26.4

†A wide-flange shape is designated by the letter W followed by the nominal depth in millimeters and the mass in kilograms per meter.

(Table continued on page 749)

Appendix C. Properties of Rolled-Steel Shapes
(SI Units)

Continued from page 751

W Shapes
(Wide-Flange Shapes)

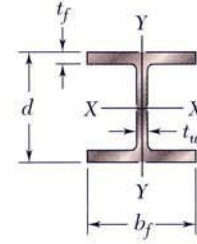

Designation†	Area A , mm ²	Depth d , mm	Flange		Web Thick- ness t_w , mm	Axis X-X			Axis Y-Y		
			Width b_f , mm	Thick- ness t_f , mm		I_x 10 ⁶ mm ⁴	S_x 10 ³ mm ³	r_x mm	I_y 10 ⁶ mm ⁴	S_y 10 ³ mm ³	r_y mm
W310 × 143	18200	323	309	22.9	14.0	348	2150	138	113	731	78.8
107	13600	311	306	17.0	10.9	248	1590	135	81.2	531	77.3
74	9480	310	205	16.3	9.4	165	1060	132	23.4	228	49.7
60	7590	303	203	13.1	7.5	129	851	130	18.3	180	49.1
52	6670	318	167	13.2	7.6	119	748	134	10.3	123	39.3
44.5	5690	313	166	11.2	6.6	99.2	634	132	8.55	103	38.8
38.7	4940	310	165	9.7	5.8	85.1	549	131	7.27	88.1	38.4
32.7	4180	313	102	10.8	6.6	65.0	415	125	1.92	37.6	21.4
23.8	3040	305	101	6.7	5.6	42.7	280	119	1.16	23.0	19.5
W250 × 167	21300	289	265	31.8	19.2	300	2080	119	98.8	746	68.1
101	12900	264	257	19.6	11.9	164	1240	113	55.5	432	65.6
80	10200	256	255	15.6	9.4	126	984	111	43.1	338	65.0
67	8580	257	204	15.7	8.9	104	809	110	22.2	218	51.0
58	7420	252	203	13.5	8.0	87.3	693	108	18.8	185	50.3
49.1	6250	247	202	11.0	7.4	70.6	572	106	15.1	150	49.2
44.8	5720	266	148	13.0	7.6	71.1	535	111	7.03	95.0	35.1
32.7	4180	258	146	9.1	6.1	48.9	379	108	4.73	64.8	33.7
28.4	3630	260	102	10.0	6.4	40.0	308	105	1.78	34.9	22.1
22.3	2850	254	102	6.9	5.8	28.9	228	101	1.23	24.1	20.8
W200 × 86	11000	222	209	20.6	13.0	94.7	853	92.4	31.4	300	53.2
71	9100	216	206	17.4	10.2	76.6	709	91.7	25.4	247	52.8
59	7560	210	205	14.2	9.1	61.1	582	89.9	20.4	199	51.9
52	6660	206	204	12.6	7.9	52.7	512	89.0	17.8	175	51.7
46.1	5860	203	203	11.0	7.2	45.5	448	87.9	15.3	151	51.1
41.7	5310	205	166	11.8	7.2	40.9	399	87.8	9.01	109	41.2
35.9	4580	201	165	10.2	6.2	34.4	342	86.7	7.64	92.6	40.8
31.3	4000	210	134	10.2	6.4	31.4	299	88.6	4.1	61.2	32.0
26.6	3390	207	133	8.4	5.8	25.8	249	87.2	3.3	49.6	31.2
22.5	2860	206	102	8.0	6.2	20.0	194	83.6	1.42	27.8	22.3
19.3	2480	203	102	6.5	5.8	16.6	164	81.8	1.15	22.5	21.5
W150 × 37.1	4730	162	154	11.6	8.1	22.2	274	68.5	7.07	91.8	38.7
29.8	3790	157	153	9.3	6.6	17.2	219	67.4	5.56	72.7	38.3
24.0	3060	160	102	10.3	6.6	13.4	168	66.2	1.83	35.9	24.5
18.0	2290	153	102	7.1	5.8	9.17	120	63.3	1.26	24.7	23.5
13.5	1730	150	100	5.5	4.3	6.87	91.6	63.0	0.918	18.4	23.0
W130 × 28.1	3580	131	128	10.9	6.9	10.9	166	55.2	3.81	59.5	32.6
23.8	3010	127	127	9.1	6.1	8.80	139	54.1	3.11	49.0	32.1
W100 × 19.3	2480	106	103	8.8	7.1	4.77	90.0	43.9	1.61	31.3	25.5

†A wide-flange shape is designated by the letter W followed by the nominal depth in millimeters and the mass in kilograms per meter.

Appendix C. Properties of Rolled-Steel Shapes (SI Units)

S Shapes (American Standard Shapes)

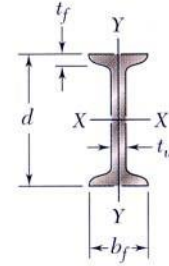

Designation†	Area A , mm ²	Depth d , mm	Flange		Web Thick- ness t_w , mm	Axis X-X			Axis Y-Y		
			Width b_f , mm	Thick- ness t_f , mm		I_x 10 ⁶ mm ⁴	S_x 10 ³ mm ³	r_x mm	I_y 10 ⁶ mm ⁴	S_y 10 ³ mm ³	r_y mm
S610 × 180	22900	622	204	27.7	20.3	1320	4240	240	34.9	341	39.0
158	20100	622	200	27.7	15.7	1230	3950	247	32.5	321	39.9
149	19000	610	184	22.1	18.9	995	3260	229	20.2	215	32.3
134	17100	610	181	22.1	15.9	938	3080	234	19.0	206	33.0
119	15200	610	178	22.1	12.7	878	2880	240	17.9	198	34.0
S510 × 143	18200	516	183	23.4	20.3	700	2710	196	21.3	228	33.9
128	16400	516	179	23.4	16.8	658	2550	200	19.7	216	34.4
112	14200	508	162	20.2	16.1	530	2090	193	12.6	152	29.5
98.3	12500	508	159	20.2	12.8	495	1950	199	11.8	145	30.4
S460 × 104	13300	457	159	17.6	18.1	385	1685	170	10.4	127	27.5
81.4	10400	457	152	17.6	11.7	333	1460	179	8.83	113	28.8
S380 × 74	9500	381	143	15.6	14.0	201	1060	145	6.65	90.8	26.1
64	8150	381	140	15.8	10.4	185	971	151	6.15	85.7	27.1
S310 × 74	9480	305	139	16.7	17.4	126	826	115	6.69	93.2	26.1
60.7	7730	305	133	16.7	11.7	113	741	121	5.73	83.6	26.8
52	6650	305	129	13.8	10.9	95.3	625	120	4.19	63.6	24.8
47.3	6040	305	127	13.8	8.9	90.5	593	122	3.97	61.1	25.3
S250 × 52	6670	254	126	12.5	15.1	61.2	482	95.8	3.59	55.7	22.9
37.8	4820	254	118	12.5	7.9	51.1	402	103	2.86	47.5	24.1
S200 × 34	4370	203	106	10.8	11.2	26.8	264	78.3	1.83	33.8	20.2
27.4	3500	203	102	10.8	6.9	23.9	235	82.6	1.60	30.6	21.1
S150 × 25.7	3270	152	91	9.1	11.8	10.8	142	57.5	1.00	21.3	17.2
18.6	2370	152	85	9.1	5.8	9.11	120	62.0	0.782	18.0	18.0
S130 × 15	1890	127	76	8.3	5.4	5.07	79.8	51.8	0.513	13.2	16.3
S100 × 14.1	1800	102	71	7.4	8.3	2.82	55.3	39.6	0.383	10.5	14.4
11.5	1460	102	68	7.4	4.9	2.53	49.6	41.6	0.328	9.41	14.8
S75 × 11.2	1430	76	64	6.6	8.9	1.20	31.6	29.0	0.254	7.72	13.1
8.5	1070	76	59	6.6	4.3	1.03	27.1	31.0	0.190	6.44	13.3

†An American Standard Beam is designated by the letter S followed by the nominal depth in millimeters and the mass in kilograms per meter.

Appendix C. Properties of Rolled-Steel Shapes (SI Units)

C Shapes (American Standard Channels)

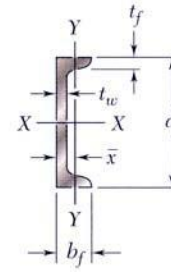

Designation†	Area A , mm ²	Depth d , mm	Flange		Web Thick- ness t_w , mm	Axis X-X			Axis Y-Y			
			Width b_f , mm	Thick- ness t_f , mm		I_x 10 ⁶ mm ⁴	S_x 10 ³ mm ³	r_x mm	I_y 10 ⁶ mm ⁴	S_y 10 ³ mm ³	r_y mm	\bar{x} mm
C380 × 74	9480	381	94	16.5	18.2	167	877	133	4.54	61.5	21.9	20.2
60	7570	381	89	16.5	13.2	144	756	138	3.79	54.7	22.4	19.7
50.4	6430	381	86	16.5	10.2	134	688	143	3.34	50.5	22.8	19.9
C310 × 45	5690	305	80	12.7	13.0	67.2	441	109	2.09	33.2	19.2	17.0
37	4720	305	77	12.7	9.8	59.7	391	112	1.83	30.5	19.7	17.0
30.8	3920	305	74	12.7	7.2	53.4	350	117	1.57	27.7	20.0	17.4
C250 × 45	5670	254	76	11.1	17.1	42.7	336	86.8	1.58	26.5	16.7	16.3
37	4750	254	73	11.1	13.4	37.9	298	89.3	1.38	24.0	17.0	15.6
30	3780	254	69	11.1	9.6	32.6	257	92.9	1.14	21.2	17.4	15.3
22.8	2880	254	65	11.1	6.1	27.7	218	98.1	0.912	18.5	17.8	15.8
C230 × 30	3800	229	67	10.5	11.4	25.4	222	81.8	0.997	19.1	16.2	14.7
22	2840	229	63	10.5	7.2	21.2	185	86.4	0.796	16.5	16.7	14.9
19.9	2530	229	61	10.5	5.9	19.8	173	88.5	0.708	15.4	16.7	15.0
C200 × 27.9	3560	203	64	9.9	12.4	18.2	179	71.5	0.817	16.4	15.1	14.3
20.5	2660	203	59	9.9	7.7	14.9	147	75.7	0.620	13.7	15.4	13.9
17.1	2170	203	57	9.9	5.6	13.4	132	78.6	0.538	12.6	15.7	14.4
C180 × 18.2	2310	178	55	9.3	8.0	10.0	112	65.8	0.470	11.2	14.3	13.1
14.6	1850	178	53	9.3	5.3	8.83	99.2	69.1	0.400	10.2	14.7	13.7
C150 × 19.3	2450	152	54	8.7	11.1	7.11	93.6	53.9	0.420	10.2	13.1	12.9
15.6	1980	152	51	8.7	8.0	6.21	81.7	56.0	0.347	9.01	13.2	12.5
12.2	1540	152	48	8.7	5.1	5.35	70.4	58.9	0.276	7.82	13.4	12.7
C130 × 13	1710	127	48	8.1	8.3	3.70	58.3	46.5	0.264	7.37	12.4	12.2
10.4	1310	127	47	8.1	4.8	3.25	51.2	49.8	0.229	6.74	13.2	13.0
C100 × 10.8	1370	102	43	7.5	8.2	1.90	37.3	37.2	0.172	5.44	11.2	11.4
8.0	1020	102	40	7.5	4.7	1.61	31.6	39.7	0.130	4.56	11.3	11.5
C75 × 8.9	1130	76.2	40	6.9	9.0	0.850	22.3	27.4	0.122	4.25	10.4	11.3
7.4	936	76.2	37	6.9	6.6	0.751	19.7	28.3	0.0948	3.62	10.1	10.8
6.1	765	76.2	35	6.9	4.3	0.671	17.6	29.6	0.0765	3.16	10.0	10.8

†An American Standard Channel is designated by the letter C followed by the nominal depth in millimeters and the mass in kilograms per meter.

Appendix C. Properties of Rolled-Steel Shapes
(SI Units)

Angles
Equal Legs

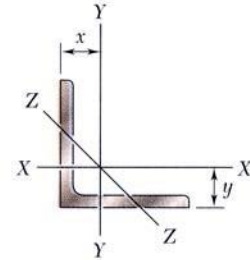

Size and Thickness, mm	Mass per Meter, Kg/m	Area, mm ²	Axis X-X and Axis Y-Y				Axis Z-Z
			<i>I</i> 10 ⁶ mm ⁴	<i>S</i> 10 ³ mm ³	<i>r</i> mm	<i>x</i> or <i>y</i> mm	<i>r</i> mm
L203 × 203 × 25.4	75.9	9670	36.9	258	61.8	60.0	39.7
19.0	57.9	7350	28.9	199	62.7	57.8	40.0
12.7	39.3	4990	20.2	137	63.6	55.5	40.4
L152 × 152 × 25.4	55.7	7080	14.6	139	45.4	47.2	29.5
19.0	42.7	5420	11.6	108	46.3	44.9	29.7
15.9	36.0	4580	10.0	92.5	46.7	43.9	29.9
12.7	29.2	3700	8.22	75.2	47.1	42.7	30.0
9.5	22.2	2800	6.34	57.4	47.6	41.5	30.2
L127 × 127 × 19.0	35.1	4470	6.54	74.0	38.3	38.6	24.7
15.9	29.8	3790	5.66	63.2	38.6	37.5	24.8
12.7	24.1	3060	4.68	51.7	39.1	36.5	25.0
9.5	18.3	2320	3.63	39.6	39.6	35.3	25.1
L102 × 102 × 19.0	27.5	3520	3.23	46.3	30.3	32.3	19.9
15.9	23.4	2990	2.81	39.7	30.7	31.3	19.9
12.7	19.0	2430	2.34	32.6	31.0	30.2	19.9
9.5	14.6	1850	1.83	25.1	31.5	29.0	20.0
6.4	9.8	1260	1.29	17.4	32.0	28.0	20.3
L89 × 89 × 12.7	16.5	2100	1.52	24.5	26.9	26.9	17.4
9.5	12.6	1600	1.19	18.8	27.3	25.8	17.4
6.4	8.6	1100	0.845	13.1	27.7	24.6	17.6
L76 × 76 × 12.7	14.0	1770	0.915	17.5	22.7	23.6	14.8
9.5	10.7	1350	0.725	13.6	23.2	22.5	14.9
6.4	7.3	932	0.517	9.50	23.6	21.4	15.0
L64 × 64 × 12.7	11.4	1460	0.524	12.1	18.9	20.6	12.5
9.5	8.7	1130	0.419	9.40	19.3	19.4	12.5
6.4	6.1	778	0.302	6.62	19.7	18.4	12.6
4.8	4.6	591	0.235	5.09	19.9	17.8	12.7
L51 × 51 × 9.5	7.0	879	0.202	5.80	15.2	16.2	9.95
6.4	4.7	612	0.147	4.09	15.5	15.1	9.94
3.2	2.4	316	0.0806	2.17	16.0	13.9	10.1

Appendix C. Properties of Rolled-Steel Shapes (SI Units)

Angles Unequal Legs

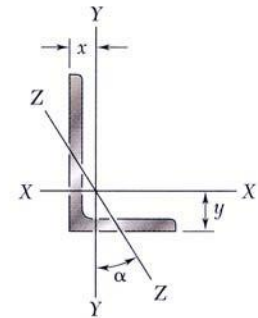

Size and Thickness, mm	Mass per Meter kg/m	Area mm ²	Axis X-X				Axis Y-Y				Axis Z-Z	
			I_x 10 ⁶ mm ⁴	S_x 10 ³ mm ³	r_x mm	y mm	I_y 10 ⁶ mm ⁴	S_y 10 ³ mm ³	r_y mm	x mm	r_z mm	$\tan \alpha$
L203 × 152 × 25.4	65.5	8370	33.5	247	63.3	67.4	16.0	145	43.7	41.9	32.4	0.541
19.0	50.1	6380	26.2	190	64.1	65.1	12.7	113	44.6	39.6	32.7	0.551
12.7	34.1	4350	18.4	131	65.0	62.7	8.96	78.1	45.4	37.3	33.0	0.556
L152 × 102 × 19.0	35.0	4470	10.1	102	47.5	52.5	3.65	49.0	28.6	27.5	21.9	0.435
12.7	24.0	3060	7.20	70.8	48.5	50.3	2.64	34.4	29.4	25.3	22.2	0.446
9.5	18.2	2320	5.56	54.0	49.0	49.1	2.06	26.4	29.8	24.1	22.4	0.452
L127 × 76 × 12.7	19.0	2420	3.93	47.6	40.3	44.4	1.06	18.6	20.9	19.0	16.3	0.355
9.5	14.5	1840	3.06	36.6	40.8	43.3	0.841	14.5	21.4	17.8	16.6	0.362
6.4	9.8	1260	2.14	25.2	41.2	42.1	0.598	10.1	21.8	16.6	16.8	0.369
L102 × 76 × 12.7	16.4	2100	2.12	31.1	31.8	33.9	1.00	18.1	21.8	20.9	16.2	0.536
9.5	12.6	1600	1.66	24.0	32.2	32.8	0.792	14.1	22.2	19.8	16.3	0.545
6.4	8.6	1100	1.17	16.6	32.6	31.6	0.564	9.83	22.6	18.6	16.5	0.552
L89 × 64 × 12.7	13.9	1780	1.36	23.3	27.6	30.6	0.581	12.7	18.1	18.1	13.7	0.491
9.5	10.7	1360	1.07	18.0	28.0	29.5	0.463	9.83	18.5	16.9	13.8	0.503
6.4	7.3	938	0.759	12.5	28.4	28.3	0.333	6.91	18.8	15.8	13.9	0.512
L76 × 51 × 12.7	11.5	1450	0.795	16.4	23.4	27.4	0.283	7.84	14.0	14.9	10.9	0.420
9.5	8.8	1120	0.632	12.7	23.8	26.2	0.228	6.11	14.3	13.7	10.9	0.434
6.4	6.1	772	0.453	8.90	24.2	25.1	0.166	4.32	14.7	12.6	11.1	0.446
L64 × 51 × 9.5	7.9	1000	0.388	9.10	19.5	21.3	0.217	5.99	14.7	14.8	10.8	0.610
6.4	5.4	695	0.280	6.39	20.1	20.2	0.158	4.24	15.1	13.7	10.8	0.621